

# Installation Instructions

**Warning: Do cut off electrical source in order to avoid electrical shock and endanger life-safety before installation.**

Model	Power	Input Voltage
NG-PTA-60W	60W	120~277V 50/60Hz
NG-PTA-80W	80W	120~277V 50/60Hz
NG-PTA-100W	100W	120~277V 50/60Hz
NG-PTA-150W	150W	120~277V 50/60Hz

Step 1: Pass the leads of the lights through the stem, then fix the stem with the lamp.

Step 2: Pass the leads of the light through the tenon pole, then using screws to fix it.

Step 3: Electrical connections:

connect the black wire to line

connect the white wire to neutral

connect the green or green/yellow wire to ground

And good waterproof processing.

LINE	—●—	BLK
NEU	—●—	WHI
GRND	—●—	REN, GRN/YEL

Step 4: On the lamps and lanterns hung up safety rope, and then install the lamp on the mast.

※Install height from floor higher than 1.2m.

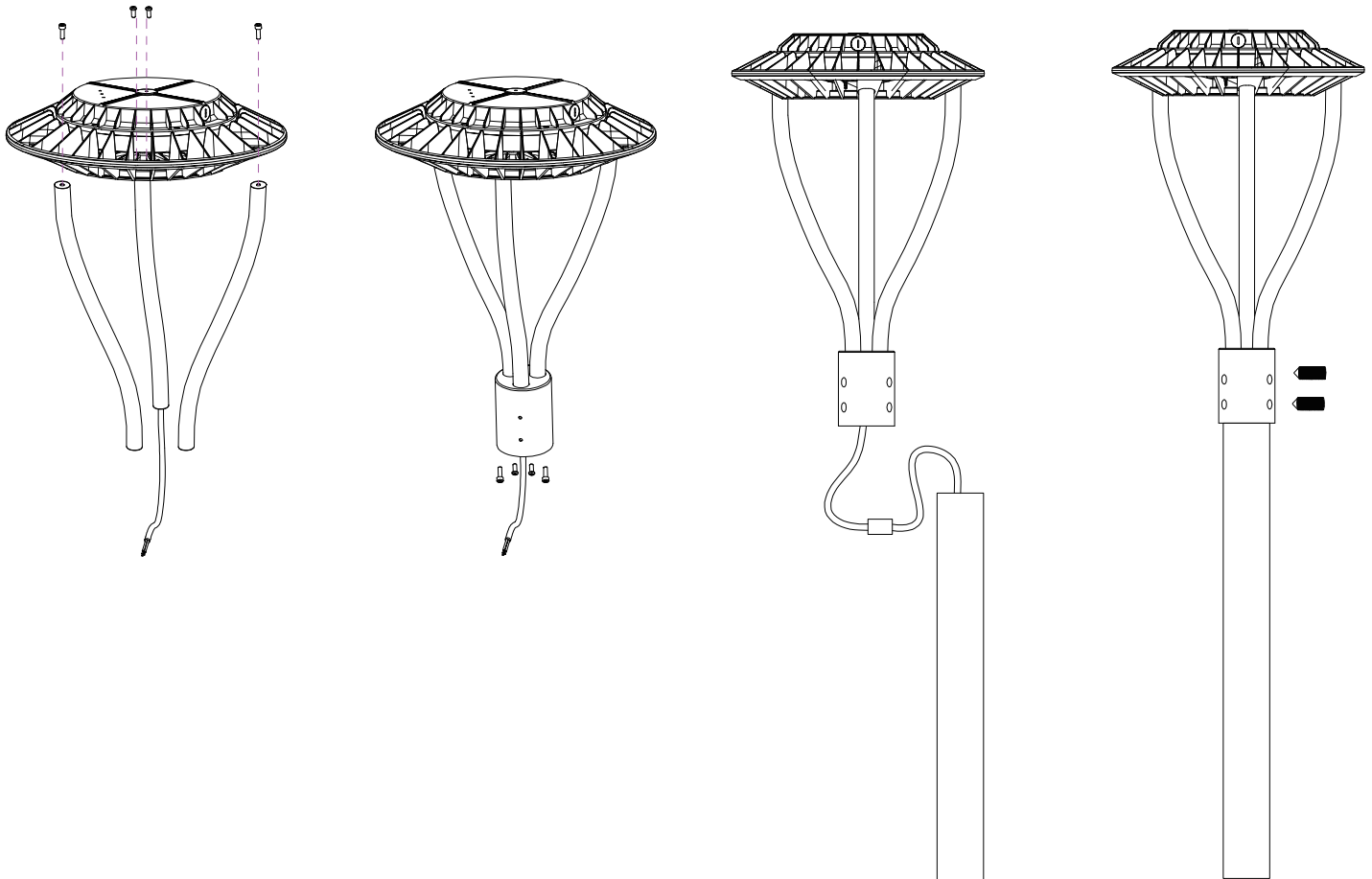

## How to adjust the color temperature of the light

Warm Notice:

1: Please turn off the light before adjusting CCT.

2: Only turn on the light after you finished the CCT selection.

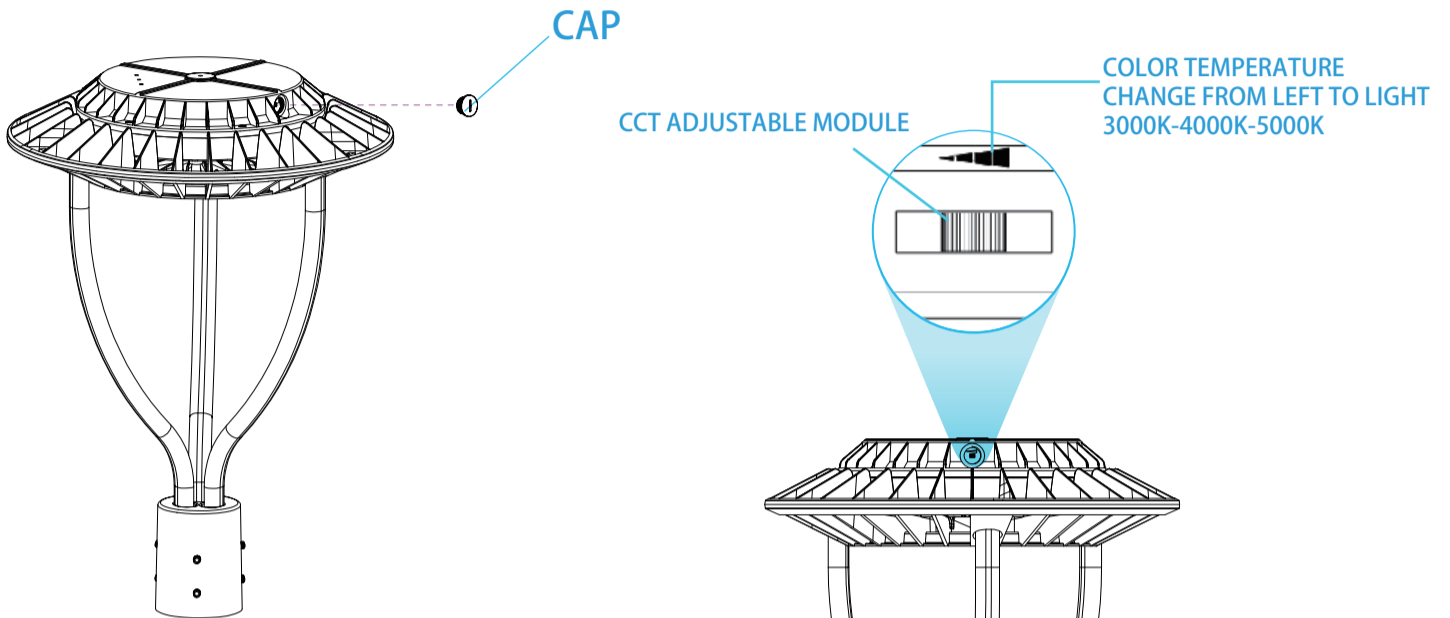

1: Unscrew the cap of slotted screw

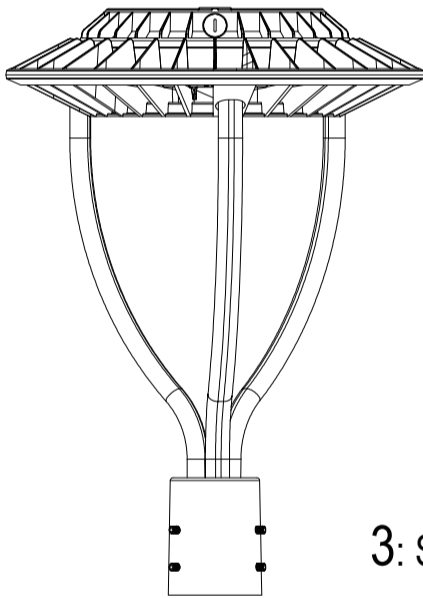

2: Select proper color temperature

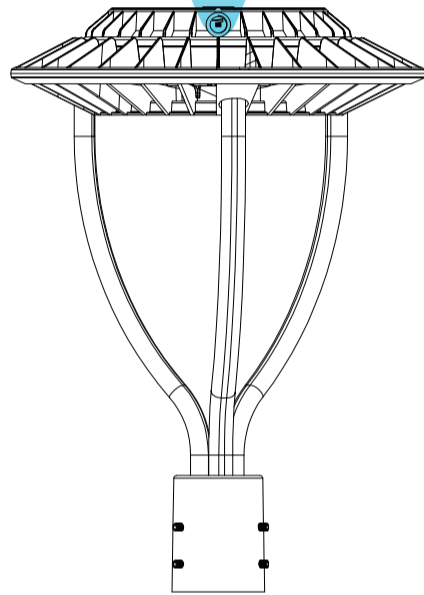

3: Screw the cap after CCT selection

