

LED POST CIRCLE AREA LIGHT

- HIGH QUALITY LIGHTING
- EASY INSTALLATION
- SAFE AND ENVIRONMENTALLY FRIENDLY
- WATERPROOF AND DURABLE
- SAVING ENERGY



CCT & Wattage Selector Switch

Photocell Sensor



Features

- 60~150W available
- IP65 waterproof dust free
- Energy saving 50% at least
- ETL cETL DLC approved
- 3000K 4000K or 5000K CCT selectable options
- Adjustable wattages: 60%/ 80%/ 100%
- 150LM/W SMD2835 chips
- 5-Years warranty
- Unicersal voltage AC100~277V
- 60°/ 90°/ 120° beam angle
- High power factor>0.9, low THD driver
- Available with photocell sensor
- Using high quality LED chips
- High intensity and stability, no maintenance cost
- Anti-shok, anti-moisture, no glare, no strobe light
- Protecting your eyes.

Applications

LED Post Circle Area Lighting series can be tidely used in city expressway, trunk road, factories, schools, garden, parking lots, public parks etc.

Series	Lumens	LED Type	Beam Angle (Degree)	Electrical Data	LED Type	Color temperature	Color rendering index
NG-PCA-60W	9000 Lm	240 PCS <small>(120PCS - 3000K) (120PCS - 5000K)</small>	60°/ 90°/ 120°	Input Voltage 100-277V 50~60Hz Total Power(W) 60W 80W 100W 150W Power Factor(%) >90	SMD 2835 chips	WW 3000K NW 4000K DW 5000K CW 5700K	Ra>80
NG-PCA-80W	12000 Lm	240 PCS <small>(120PCS - 3000K) (120PCS - 5000K)</small>					
NG-PCA-100W	15000 Lm	360 PCS <small>(180PCS - 3000K) (180PCS - 5000K)</small>					
NG-PCA-150W	22500 Lm	360 PCS <small>(180PCS - 3000K) (180PCS - 5000K)</small>					

60W/80W/100W/150W

Weight: 3200g/ 7.05 lbs

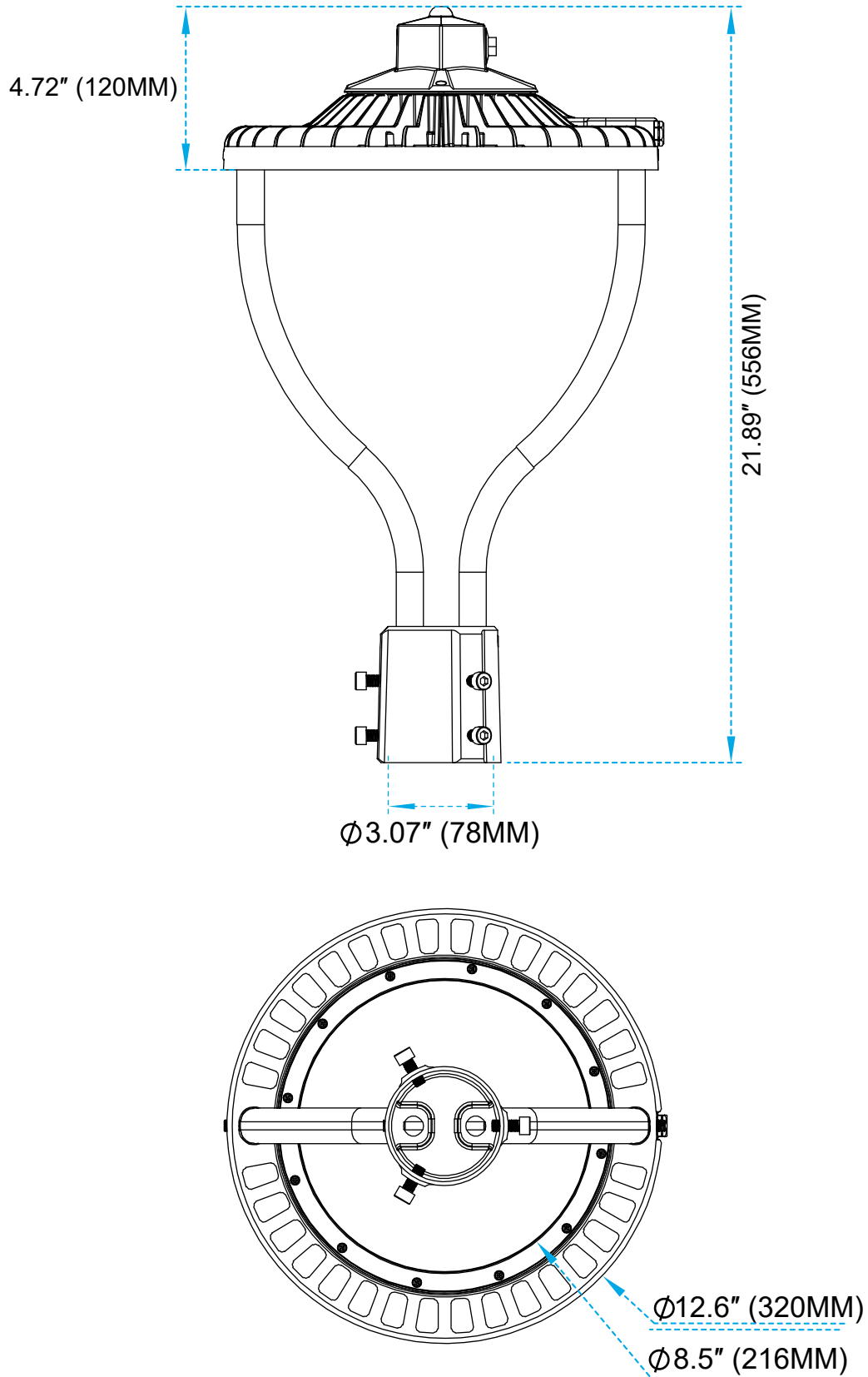

Installation Instructions

Warning: Disconnect power before installation to prevent electric shock, death, or serious injury.

Model	Power	Input Voltage
NG-PCA-60W	60W	100~277V 50/60Hz
NG-PCA-80W	80W	100~277V 50/60Hz
NG-PCA-100W	100W	100~277V 50/60Hz
NG-PCA-150W	150W	100~277V 50/60Hz

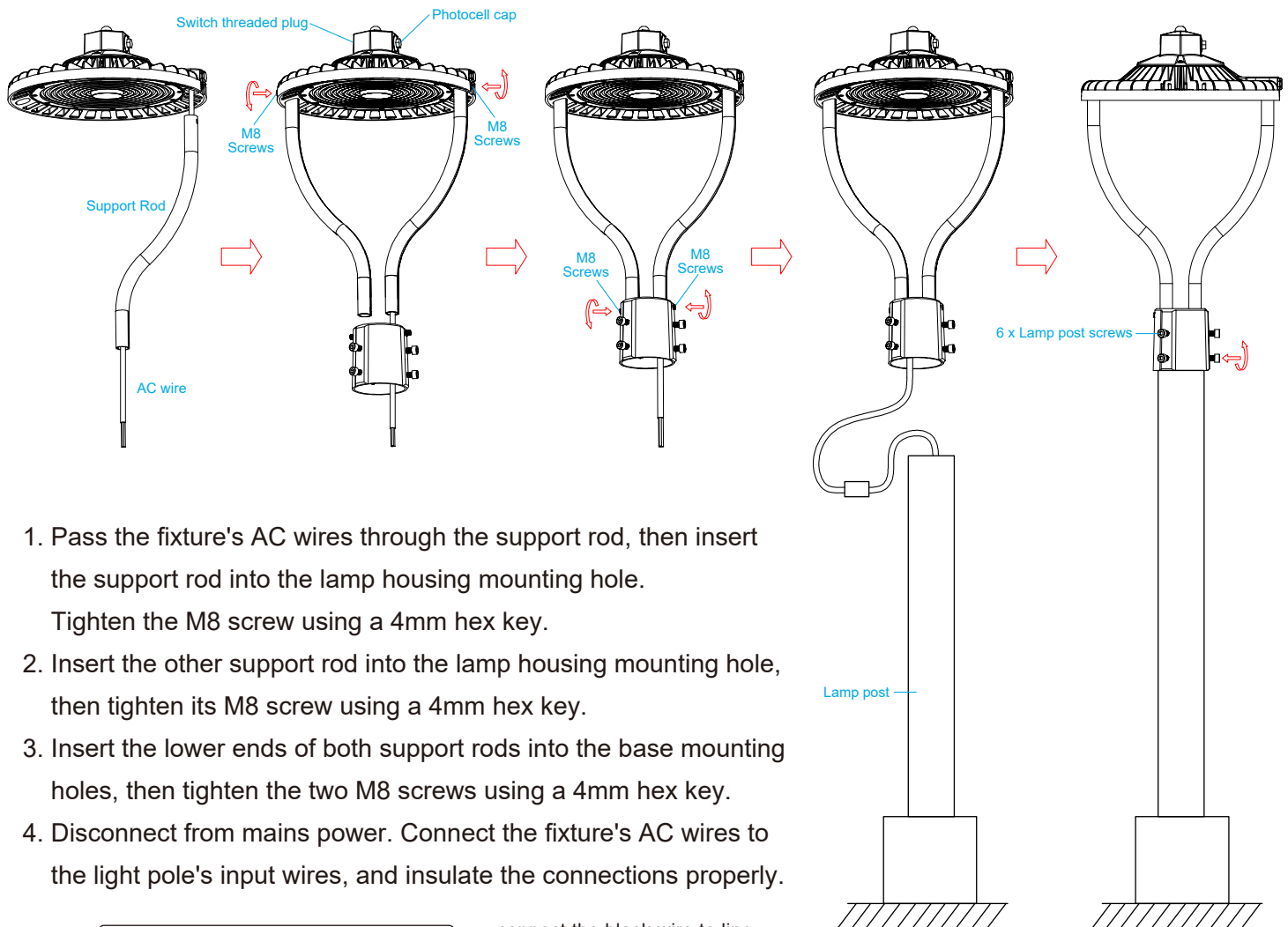

1. Pass the fixture's AC wires through the support rod, then insert the support rod into the lamp housing mounting hole. Tighten the M8 screw using a 4mm hex key.
2. Insert the other support rod into the lamp housing mounting hole, then tighten its M8 screw using a 4mm hex key.
3. Insert the lower ends of both support rods into the base mounting holes, then tighten the two M8 screws using a 4mm hex key.
4. Disconnect from mains power. Connect the fixture's AC wires to the light pole's input wires, and insulate the connections properly.

LINE	●	BLK
NEU	●	WHI
GRND	●	REN,GRN/YEL

connect the black wire to line
 connect the white wire to neutral
 connect the green or green/yellow wire to ground
 And good waterproof processing.

5. Insert the fixture onto the lamp post and tighten the 6 pole screws using a 6mm hex key.
6. Unscrew the switch threaded plug, adjust to the desired CCT & power, then retighten the threaded plug.
7. Pull the light sensor cap if the light-sensing function is required.
8. Power on to illuminate the fixture.

How to Adjust the Light Temperature

Important Notice:

1. Please turn off the light before adjusting the power and CCT (Correlated Color Temperature).
2. Turn the light back on only after you have completed your power and CCT selection.

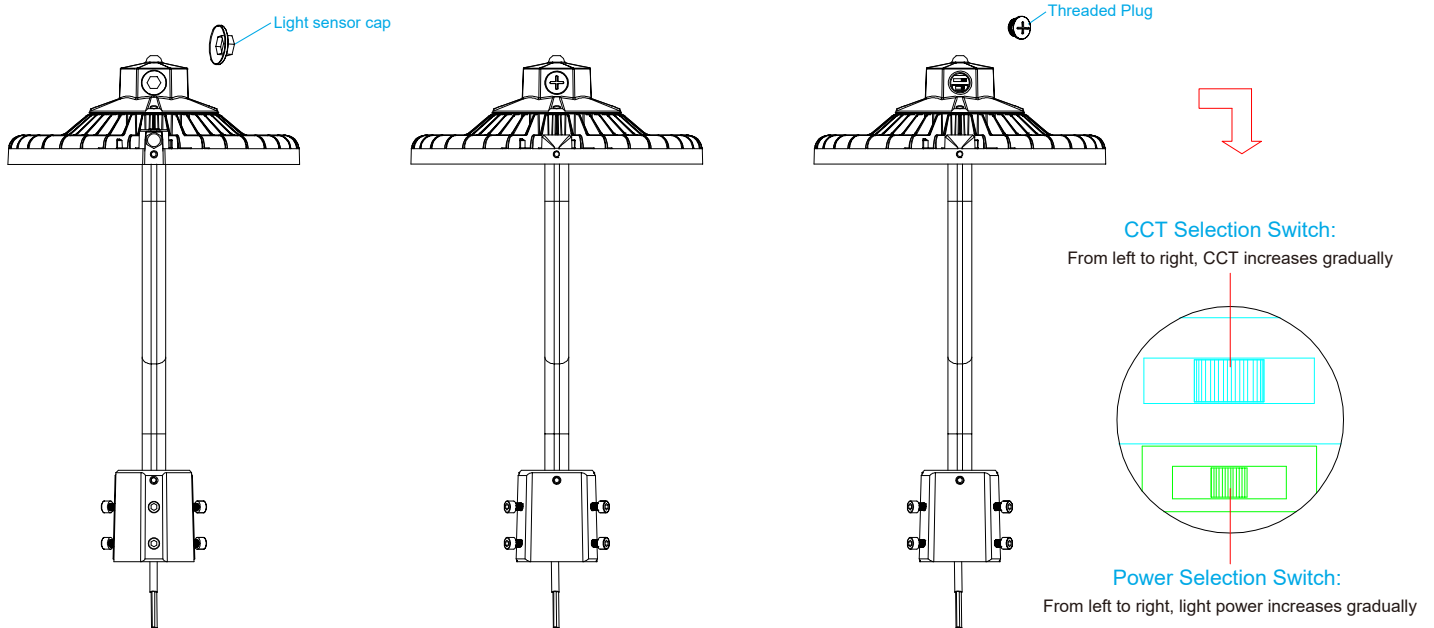

1. With the power off, unscrew the switch threaded plug.
2. Toggle the adjustment switch to set the desired CCT & power.
3. After adjustment, tighten the switch threaded plug securely.
4. If light-sensing function is needed, remove the light sensor cap.

CCT Selections:

There are 3 color temperatures available (CW/NW/WW)
 Please select the color temperature you prefer before installation

WW	NW	CW
3000K	4000K	5000K

Power Selections:

There are 3 power options (L/M/H), please select the power according to your needs

PCA-60W	L(60%)	M(80%)	H(100%)
	36W	48W	60W

PCA-80W	L(60%)	M(80%)	H(100%)
	48W	64W	80W

PCA-100W	L(60%)	M(80%)	H(100%)
	60W	80W	100W

PCA-150W	L(60%)	M(80%)	H(100%)
	90W	120W	150W

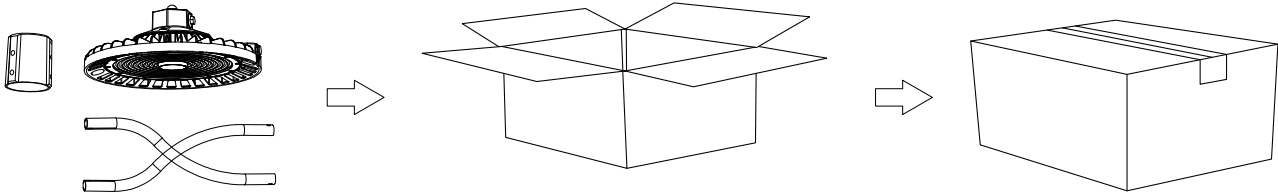

POWER	Unit	Size	Gross Weight	Volume
NG-PCA-60W NG-PCA-80W	1PCS	420*380*155mm / 16.54"*14.96"*6.1"	4.2 Kg / 9.26 lbs	0.038m ³
NG-PCA-100W NG-PCA-150W	3PCS	515*435*405mm / 20.28"*17.13"*15.94"	13.5 Kg / 29.76 lbs	0.093m ³