

# VAPOR SERIES TRI-PROOF LIGHT

Wattages: 12W, 15W, 18W, 22W, 25W, 30W, 35W, 40W, 50W, 60W, 70W, 80W, 100W



VAPOR series tri-proof light is designed for places requiring waterproof, dustproof and slight corrosion-resistant lighting, such as warehouse, parking lot, food factory, dust factory, cold storage etc. It can be used in places requiring corrosion-resistant lighting. While common tri-proof light cannot reach this requirement-Photoelectric separation design and LED lifespan is up to 50000 hours



## PRODUCT FEATURES

- Integrated design of the lampshade and the fixing plate of lamp panel makes it more convenient for wiring, saving more than half of the installation time.
- The reserved screw holes in clamp are for shockproof.
- Photoelectric separation for effective heat dissipation.
- High-light-transmittance cover, high luminous efficacy, uniform and soft light, 140LM/W
- Excellent waterproof performance IP65.
- Operating temperature range: -40°C-45°C.
- 2 types of installation: ceiling bracket and lifting rope.
- Corrosion-resistant grade: slight corrosion-resistant.

## PRODUCT DIMENSION

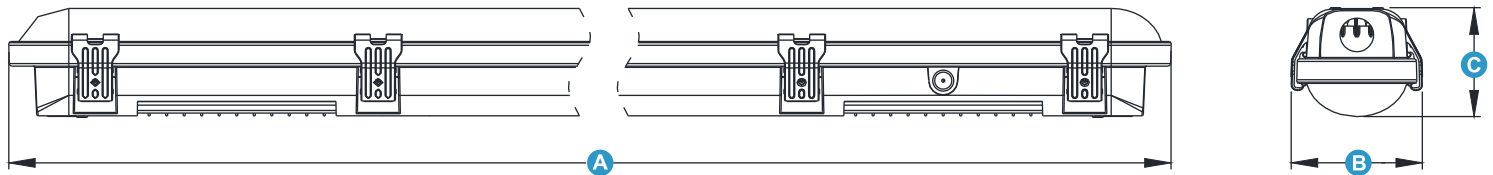

Specification	Power	A	B	C
0.6M	30W	600mm	95mm	80mm
1.2M	50W	1200mm	95mm	80mm
2.4M	100W	2400mm	95mm	80mm

# VAP SERIES TRI-PROOF LIGHT

Wattages: 12W, 15W, 18W, 22W, 25W, 30W, 35W, 40W, 50W, 60W, 70W, 80W, 100W

## PRODUCT PARAMETERS

Model Number	Wattage	Working Voltage	CCT	Lamp Bead Model	Beam Angle	EFFICACY	CRI	Operating Temperature	Storage Temperature	Environment Location	Life span	Lamp
NG-VAP-T-25W-H-TCP	25/22/18/ 15/12W	AC 120-277	3500K 4000K 5000K 5700K 6500K	2835	120°	125lm/W	Ra>80	-40°F~113°F -40°C~45°C	-40°F~ 158°F -40°C~70°C	Wet Location	≥50000H	White
NG-VAP-F-50W-H-TCP	50/40/35/ 30/25W											
NG-VAP-E-100W-H-TCP	100/80/70/ 60/50W											
NG-VAP-T-25W-H-MV-TCP	25/22/18/ 15/12W	AC 120-347	3500K 4000K 5000K 5700K 6500K									
NG-VAP-F-50W-H-MV-TCP	50/40/35/ 30/25W											
NG-VAP-E-100W-H-MV-TCP	100/80/70/ 60/50W											

T=2FT, F=4FT, E=8FT, H=120-277V, H-MV=120-347V, XXK=Indicates specific color temperature, TCP=Color temperature adjustable

## INSTALLATION REQUIREMENT

1. Power off before installation.
2. Thread the input cable through waterproof joint then combine the input thread and wiring terminals, and ensure reliable contact.
3. Tighten the knob bracket.
4. Ceiling installation: fix the ceiling bracket on the installation surface via self-tapping screws and flat gasket then snap the lamp body into bracket.

## INSTALLATION DRAWING

### Ceiling Installation

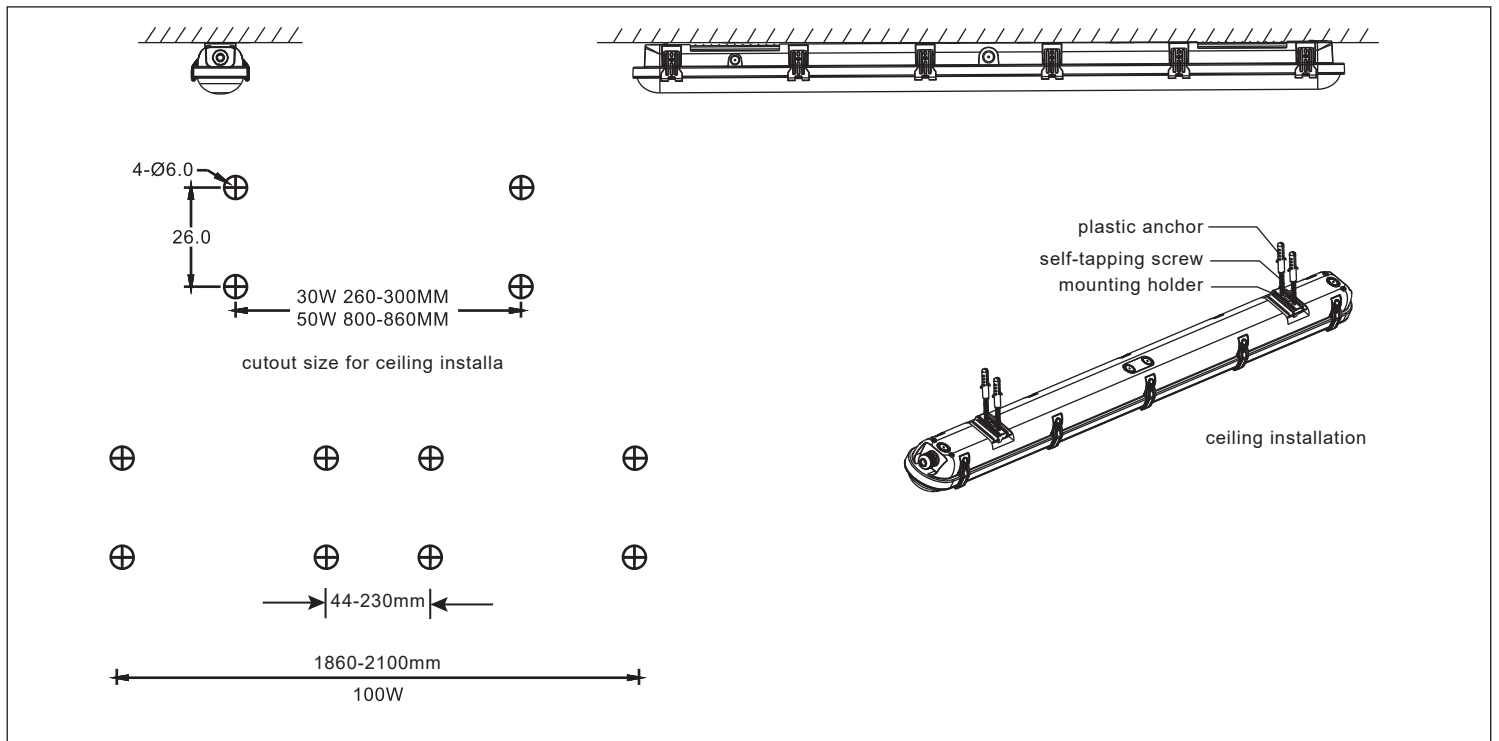

# VAP SERIES TRI-PROOF LIGHT



Wattages: 12W, 15W, 18W, 22W, 25W, 30W, 35W, 40W, 50W, 60W, 70W, 80W, 100W

## Suspendent Installation

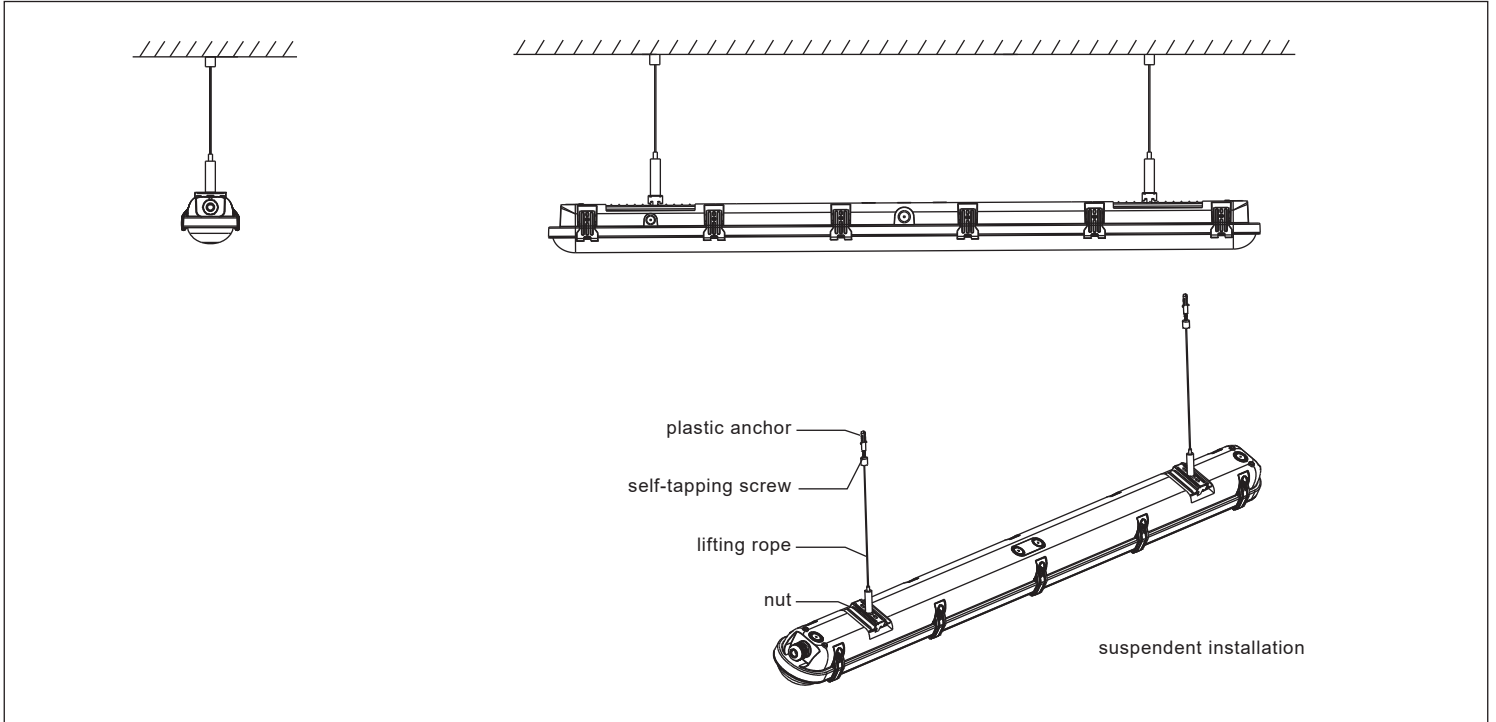

## CONNECTION DIAGRAM

Refer To The Wiring Diagram For Wiring.

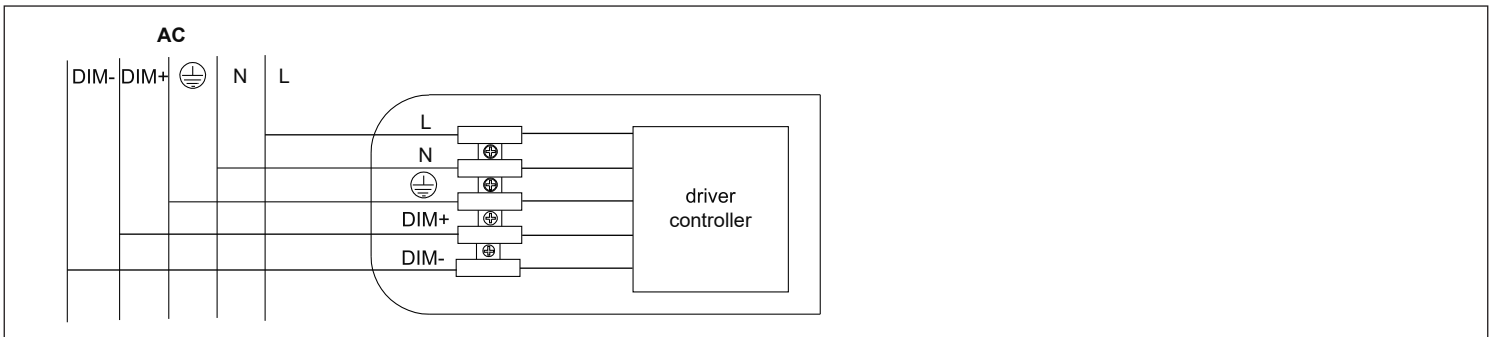

Web: [www.ngtlight.com](http://www.ngtlight.com) | Email: [sales@ngtlight.com](mailto:sales@ngtlight.com)

NGTLIGHT LLC Warehouse: CA & OH

Oversea Factory: Huilongda Industrial Park, Shilongzai, Shiyan Town, Shenzhen, P.R.China.

# VAP SERIES TRI-PROOF LIGHT



Wattages: 12W, 15W, 18W, 22W, 25W, 30W, 35W, 40W, 50W, 60W, 70W, 80W, 100W

## PACKGING / WEIGHT

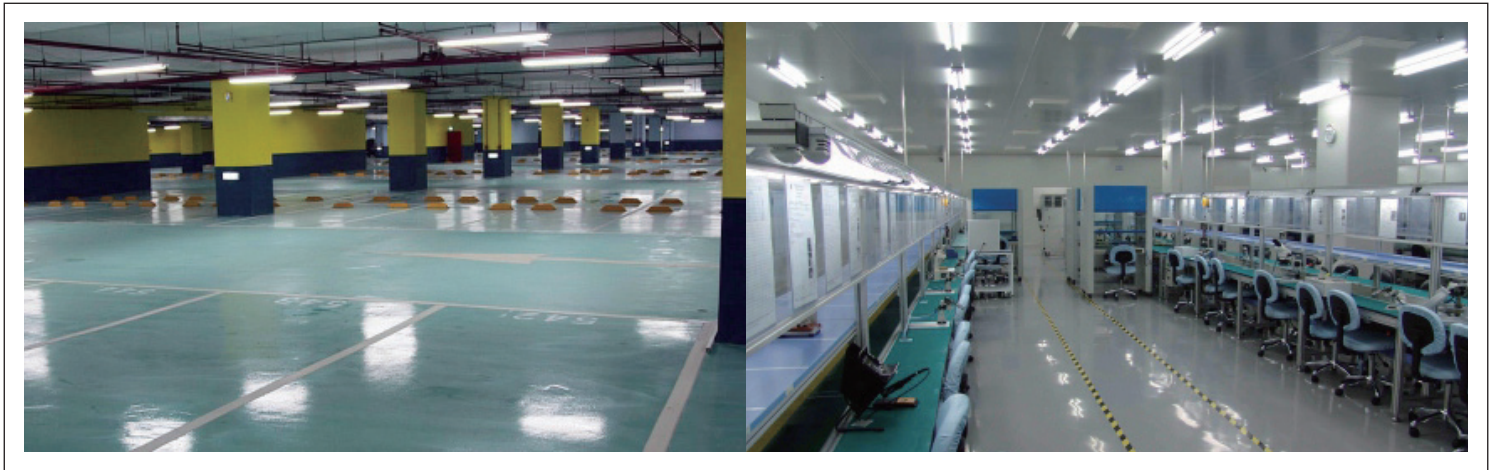

	Inner Packing Size	Outer Packing Size	Net Weight	Gross Weight	Qty
0.6M	650*107*102mm 25.59*4.21*4.02 inch	665*356*371mm 26.18*14.02*14.61 inch	11.96 KG 26.37 LBS	12.76 KG 28.13 LBS	9
1.2M	1250*107*102mm 49.21*4.21*4.02 inch	1265*356*371mm 49.8*14.02*14.61 inch	22.2 KG 48.94 LBS	23.8 KG 52.47 LBS	9
2.4M	/	2450*107*102mm 96.46*4.21*4.02 inch	3.51 KG 7.74 LBS	4.87 KG 10.74 LBS	1



Web: [www.ngtlight.com](http://www.ngtlight.com) | Email: [sales@ngtlight.com](mailto:sales@ngtlight.com)

NGTLIGHT LLC Warehouse: CA & OH

Oversea Factory: Huilongda Industrial Park, Shilongzai, Shiyan Town. Shenzhen, P.R.China.